

CASE STUDY OF THE AUSTIN ENERGY DELL REGIONAL CHILDREN'S MEDICAL CENTER OF CENTRAL TEXAS PACKAGED HYBRID CHP ENERGY PLANT IN AUSTIN, TEXAS

July 21, 2005

Ed Mardiat & Jim Teigen, Burns & McDonnell
Cliff Braddock, Austin Energy
Jan Berry, Oak Ridge National Laboratory
Adam Newcomer, The University of Texas
Bob Moroz, Healthcare Consultant

ABSTRACT

Innovative approach to designing an integrated packaged and modular hybrid energy plant allows for improved reliability, redundancy and efficiency. Austin Energy, who will own and operate this plant, selected Burns & McDonnell as their packaged plant integrator. Austin Energy has signed an energy services agreement to provide the new hospital with power, chilled water and steam.

The plant is the first of its kind in the State of Texas using the CHP module to generate primary power for the Dell Children's Medical Center of Central Texas (DCMCCT) with the grid providing backup power. The packaged and modular CHP plant will utilize the state-of-the-art Solar Turbines Mercury 50 combustion turbine, which has a simple cycle heat rate efficiency of 38 percent and produces less than 5 ppm NOx and meets the Texas 2005 emission mandate without the need for a catalyst, counting the thermal benefits of steam and chilled water. In addition, the hybrid plant will utilize a heat recovery steam generator, packaged chiller plant and boiler, absorption cooling and thermal energy storage to maximize system efficiency, operational flexibility and reliability of services to the hospital and the campus district cooling system.

The hybrid energy plant control system will allow the system to be remotely monitored and operated from an off-site operational control center. The presentation will provide insight into the design of the hybrid energy plant and present features and benefits to this type of packaged and modular system approach. In addition to hospitals, which have a need for grid independence, universities, airports, and other critical facilities, such as data centers, will benefit from this type of packaged hybrid energy plant approach.

DCMCCT PROJECT OVERVIEW

The first phase of the DCMCCT development is a state-of-the-art 470,000 square foot, 169 bed children's hospital and parking garage, currently under construction for an estimated cost of \$110 million. The project will also include a 125,000 square foot medical office

building/parking garage and a 15,000 square foot Ronald McDonald House. The ultimate building of the DCMCCT hospital's campus is planned for more than 32 acres and 1.4 million square feet.

Another significant design factor is that the DCMCCT has established a goal of becoming the first LEED Platinum hospital in the world. The hospital and the hybrid energy plant will be submitted as a single project. The hybrid packaged CHP energy plant will be the first in the nation to be evaluated by LEED for energy efficiency credits. The project is on track to receive 8 to 10 energy efficiency points under the proposed LEED Energy & Atmosphere scoring criteria.

RELIABILITY AND REDUNDANCY

The importance for reliability and redundancy has taken a much more important role post 9-11. One of the lessons learned from 9-11 was that in time of crisis, whether the crisis is a terrorist attack, natural disaster or a major blackout such as the one that occurred in the Northeast, it is imperative that critical care facilities have the ability to have 100% of the facilities systems up and running. Prior to 9-11, most all critical care facilities only have enough on-site emergency generation for life safety and possibly a small portion of the facility up and running during a grid outage.

In addition, healthcare facilities need more reliable and higher quality power to meet the requirements of a fully "digital hospital". Once healthcare facilities convert to fully automated medical records, RFID/bar code scan drug delivery, computerized physician order entry, etc., health care delivery will stop if the "lights go out". Other critical healthcare facility power delivery issues include:

- **Cleaner Normal Power:** Local generation is anticipated to provide fewer sags and surges. Conversion from primary power to grid backup is measured in "cycles" rather than "seconds".
- **More Backup Power:** Both Grid backups supply 100% of the Hospital's needs; not just its Life

Safety requirements; imagine no chillers in Austin, Texas in August.

- **More Reliable Backup Power:** Probability of failure of the traditional Hospital “grid plus backup” is 67% according to Primen Perspective’s *RX for Health Care Power Failures*, DE-PP-24, 11/2003
- **“Island” Power:** In the event of a grid failure due to natural or terrorist causes, this strategic community asset will remain in operation when we are likely to need it most.

PACKAGED HYBRID ENERGY PLANT AND CHP SYSTEM OVERVIEW

The DCMCCT packaged hybrid CHP energy plant will be the first commercial in-site energy plant project to be owned and operated by Austin Energy. The packaged plant concept used for the DCMCCT hybrid energy plant is the result of lessons learned from the Department of Energy CHP Development Project located at the Domain Technology Business Park located in Austin. The DCMCCT hybrid energy plant will expand the concept beyond a packaged CHP plant to include all of the necessary components to provide all of the power and thermal requirements of the hospital. Burns & McDonnell was selected as the packaged plant equipment supplier and system integrator by Austin Energy as result of an extensive competitive selection process.



*Rendering Courtesy of Karlsberger

The DCMCCT hybrid CHP energy plant is a packaged or modular system using standard, pre-manufactured components. Burns & McDonnell will integrate the various package components into a pre-engineered package, where each module or component can be delivered to the site on skids. The modular system is designed to reduce the custom engineering, planning and project lead time that is standard for most CHP systems. A packaged design using standard, pre-manufactured components allows systems to be scaled up or down in size to serve a variety of situations. Integrating technologies into modular systems

that include on-site power generation, heat recovery, and thermally activated technologies is intended to achieve efficiency gains not possible from designing and building an on-site system.²

The hybrid packaged CHP energy plant will produce all of the electricity, chilled water, and steam necessary to provide 100% of the hospitals energy needs. The CHP module will provide on-site generation to serve all of the power requirements and will use two Austin Energy grid feeds as backup. It is believed that DCMCCT will be the first hospital in the State of Texas to have the capability to be operated 100% grid independent.

The heart of the hybrid energy plant is the CHP module. As part of the Burns & McDonnell proposal, Austin Energy selected the Solar Turbines Mercury 50 combustion turbine as the prime mover for the CHP module. The Mercury 50 is a state-of-the-art recuperated combustion turbine that is rated to produce 4.4 MWe of power, a heat rate of 9058 Btu/kW-hr, steam at 13.75-105.0 k/lb/hr and has guaranteed NOx emissions of 5 ppm. This is one of the only technologies available that will meet the new State of Texas emission standards without the need of a catalyst.

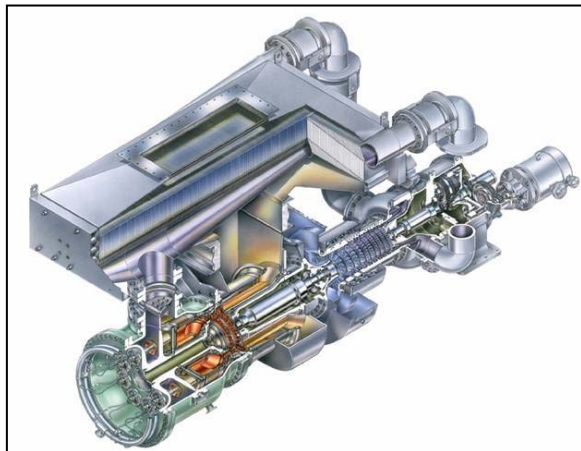

*Mercury 50 Courtesy of Solar Turbines

The waste heat from the 711° F combustion turbine exhaust, as the heat source for a heat recovery steam generator (HRSG) will produce 123.753 lbs of steam at 130 psig, without supplemental firing of the HRSG. The steam from the HRSG will be used to provide process steam for hospital sterilization and to produce approximately 950 tons of chilled water from a Trane Horizon two-stage steam absorption chiller. The overall efficiency of the CHP module, including the Mercury 50, HRSG and steam absorption chiller coincident load is estimated to be greater than 70% efficient.

Other major packaged modules making up the rest of the hybrid energy plant include the following. A 1500 kW

backup emergency engine generator, a packaged electrical duplex centrifugal chiller plant including cooling tower capacity for the both chillers, chilled water thermal energy storage (TES) tank, packaged natural gas fired standby boiler, natural gas compressor for the turbine, chemical treatment package, primary and secondary chilled water, and TES pump packages, 15 kV and 4160 volt electrical distribution switchgear, and a programmable logic controller based control integration system.

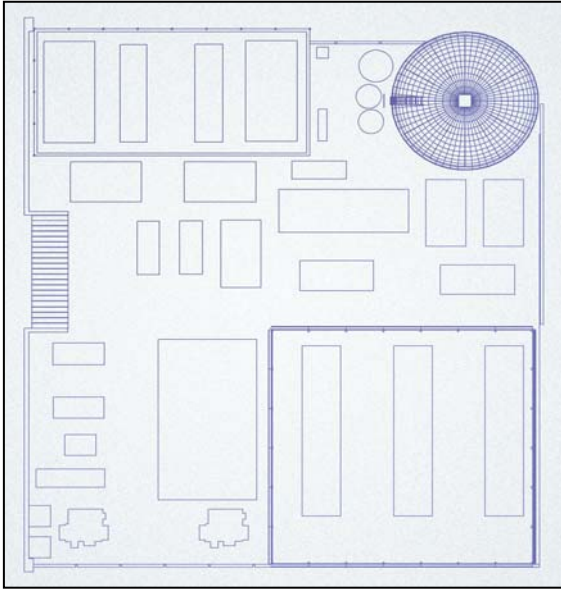

*Courtesy of Burns & McDonnell

The packaged chiller plant, which will include a Trane 1500 ton duplex electrical centrifugal chiller, chilled water and cooling water pumps, cooling towers, and motor control center will be fabricated by Turbine Air Systems and delivered to the site as an integrated packaged plant. TAS will also provide the Trane Horizon 900 tons two stage absorption chiller as part of the chilled water system package. The absorption chiller will be located adjacent to the packaged plant and weatherized for outdoor operations.

Another significant feature of the packaged hybrid CHP energy plant is the thermal energy storage tank. The tank is sized for 8000 ton-hours of storage capacity, or enough time to defer from running the electrical centrifugal chiller during the peak energy times of the day. The thermal storage tank also provides increased redundancy and reliability during non-peak periods, by allowing the stored chilled water to be used as backup to the packaged chiller plant and the absorption chiller.

PERFORMANCE MONITORING AND MEASUREMENT

The DCMCCT hybrid CHP energy plant control system is designed to allow Austin Energy to operate and monitor the plant from a central operations center located at the

Domain Technology Business Park. The Department of Energy is providing cost share funding which will be used to provide data measurement and performance monitoring equipment. The controls integration system will have an array of data sensors that monitor and record the system peak inputs and outputs as well as intermediate conditions. The controls integration system will be able to monitor and record electric and thermal data for all components of the system: the emergency standby generator, natural gas compressor, combustion turbine generator, HRSG, packaged boiler, electric centrifugal and absorption chiller, cooling tower, thermal energy storage tank and auxiliaries. The DCMCCT hybrid CHP energy plant controls integration system will produce real-time empirically verifiable performance data.

LEADERSHIP in ENERGY and ENVIRONMENTAL DESIGN

The hospital and the energy plant will be submitted to the United States Green Building Council (USGBC) as a single project. LEED®, the "Leadership in Energy & Environmental Design" Green Building Rating System, is the nationally accepted standard for green buildings developed by the USGBC membership. Breakthroughs in building science, technology and operations are available to designers, builders and owners who want to build green and maximize both economic and environmental performance.³

The hospital will receive several benefits by achieving LEED certification. These include the following: Better clinical outcomes, healthier buildings will result in healthier kids. LEED also makes economic sense by reducing initial capital cost while providing life-cycle cost savings. DCMCCT also determined that LEED certification provides a philanthropic "edge" against other healthcare facilities. Another significant benefit is in the areas of employee recruitment and retention.

The LEED certification process compares the baseline, as determined by ASHRAE 90.1 to a higher standard in this case an on-site packaged hybrid CHP energy plant. To achieve the energy efficiency points as defined in LEED-NC EA-1, we will have to demonstrate that the "on-site" hybrid energy plant is more efficient than normal central generation, transmission and distribution, or "metered" energy approach.

As part of the LEED evaluation process, an analysis to evaluate the improved efficiency of "on-site energy" as compared to the traditional efficiency of "metered energy" delivered to the hospital will be developed. The DCMCCT hybrid CHP energy plant will be the first in the country to receive energy credits under the new LEED EA-1 criteria, which now gives credit for CHP or district heating and cooling serving a building.

RESEARCH AGENDA

Burns & McDonnell was able to bring DOE cost share funding for the DCMCCT package hybrid energy plant project as part of Phase 2 of the original DOE CHP Development project. A portion of these cost share funds will be used for research, performance monitoring and the documentation of results. Burns & McDonnell has engaged The University of Texas in Austin to provide the research, analysis, documentation and results reporting for this project.

The on-site packaged hybrid CHP energy plant is anticipated to have benefits over systems using traditional grid electricity with electrical centrifugal chillers and natural gas fired packaged boilers. A research agenda was developed to determine these benefits and to compare performance to other systems. The agenda for research is designed to understand the performance of the CHP system under all operating conditions, and to determine what may be optimal operating parameters for the system. As part of the research agenda, system performance can be evaluated through thermal, electric and system efficiency measurements, as well as through identifying a family of system performance curves based on varying operating parameters.

EFFICIENCY

System performance can be monitored through measures of efficiency. Collected performance data allows for the determination of electric, thermal and system efficiency. An efficiency measurement is a useful way to compare the performance of various technologies as well as whole systems.

Efficiency for CHP systems is a more complicated measure than conventional grid electricity and HVAC equipment because there are multiple useful outputs. A challenge is to identify a measure or set of measures that best accounts for the multiple useful outputs of a CHP system given a fuel input. Another challenge is appropriately factoring in efficiency losses due to auxiliary systems, such as electric pumps, fan and controls.

CONCLUSIONS

The DCMCCT packaged hybrid CHP energy plant is a unique system designed for efficiently producing electricity, steam and cooling with low emissions and detailed performance monitoring and measurement. The system will produce empirically verifiable information. All parties involved, the local municipal utility, equipment packagers, the system integrator, Department of Energy, Oak Ridge National Laboratory and The University of Texas at Austin, are working to assess the system's performance in a manner that is accurate, transparent and verifiable. A goal of the initial performance monitoring is to provide performance data in a form that is accurate and

makes sense to energy professionals and others who may consider installing a packaged CHP system to meet electric and thermal needs in an efficient manner.

Packaged CHP systems such as the DCMCCT packaged hybrid CHP energy plant are an emerging technology that has great potential to provide users with cost effective reliable energy with low emissions. However, there are no standard mechanisms to assess system performance. In order for an end user to decide if they want to adopt this technology they need to be able to compare performance among alternative CHP systems as well as existing technologies in terms that are appropriate and meaningful. An important step in promoting packaged CHP systems is to develop measures that report system performance in a meaningful way. A next step in the research agenda is to move forward and complete this performance assessment for the DCMCCT packaged hybrid CHP energy Plant and identify the realized benefits of the packaged CHP system.

REFERENCES

- ¹ U.S. Department of Energy, Distributed Energy and Electricity Reliability Program, *Distributed Energy Resources*, Available: http://www.eere.energy.gov/de/pdfs/der_allother.pdf, Last accessed: Oct 16, 2004.
- ² United States Green Building Council Leadership in Energy and Environmental Design, *Why Build Green?*, Available: <http://www.usgbc.org/DisplayPage.aspx?CMSPageID=38> & Last accessed: Jul 1, 2005.